

CSM Series

Digital Counting Scale

Operation Manual

Revision 1.2
December 26, 2000

Transcell Technology inc.

ATTENTION:

To extend the life of your digital scale, do not drop items to be weighed onto the platform or overload the scale beyond its rated capacity. Shock-loading and overloading may damage the load cell and void the warranty.

© 2000 Transcell Technology, Inc.

Contents subject to change without notice.

Transcell Technology, Inc.
975 Deerfield Parkway
Buffalo Grove, IL 60089
Tel (847) 419-9180
Fax (847) 419-1515
E-mail: transcell@transcell.net
Web: www.transcell.net

Electromagnetic Compatibility Statement for Europe

PRODUCT	CSM	Directives with which this equipment complies:	
Harmonized Standards applied:		EMC 89/336/EEC	EMC Directive
		EMC 92/31/EEC	EMC Directive
		EMC 93/68/EEC	EMC Directive
EN 45501:1994		EN 55011:1998 (Class B	
EN 61000-3-2:1995		IEC801-2:1991	
EN 61000-3-3:1995		IEC801-3:1984	
		IEC801-4:1988	
		Short Time Power Reductions	
EN 55024: 1998		EN 61000-4-5:1995	
Year in which CE mark affixed	2000	Date of issue	May 2000

Electromagnetic Compatibility Statement for North America

This equipment has been tested and found to comply with the limits for a Class A digital device, pursuant to Part 15 of the FCC Rules. These limits are designed to provide reasonable protection against harmful interference when the equipment is operated in a commercial environment. This equipment generates, uses and can radiate radio frequency energy and, if not installed and used in accordance with the instructions manual, may cause harmful interference to radio communications. Operation of this equipment in a residential area is likely to cause harmful interference in which case the user will be required to correct the interference at his/her own expense.

TABLE OF CONTENTS

	<u>Page</u>
Chapter 1: Introduction to the Transcell CSM Series Digital Counting Scale.....	1-1
Chapter 2: Getting Started	2-1
Chapter 3: Basics of Operation	3-1
3.1 Display	3-1
3.1.1 Vacuum Fluorescent Display (VFD).....	3-1
3.2 Keyboard	3-2
3.2.1 Function and Numeric Keys	3-2
3.3 General Scale Operation	3-2
3.3.1 Weighing an Item.....	3-2
3.3.2 Taring an Item of Unknown Weight	3-3
3.3.3 Taring an Item of Known Weight	3-3
3.3.4 Clearing a Tare	3-3
3.3.5 Piece Counting.....	3-3
3.3.6 Clearing the Piece Count.....	3-4
Chapter 4: Advanced Features and Operation.....	4-1
4.1 Unit Weight Entry	4-1
4.1.1 Unit Weight Entry	4-1
4.2 Memory Accumulator.....	4-1
4.2.1 Displaying the Memory Accumulator	4-1
4.2.2 Adding to the Memory Accumulator.....	4-1
4.2.3 Clearing the Memory Accumulator	4-1
4.3 Using the Target Value	4-1
Chapter 5: Configuration	5-1
5.1 Configuration Overview	5-1
5.2 Setup (“F”) Menu	5-1
5.3 User (“A”) Menu.....	5-1
5.3.1 Entering the User Menu.....	5-1
5.3.2 Navigating in the User Menu	5-1
5.3.3 Exiting the User Menu	5-2
5.4 User Menu Procedures	5-3
5.4.1 ID Number Entry (A8).....	5-3
5.4.2 LF (Line Feeds) Number Entry (A9).....	5-4

Chapter 6:	Calibration	6-1
6.1	Calibration Overview	6-1
6.2	Calibration Mode	6-1
Appendix A:	Specifications	A-1
Appendix B:	Serial Port Information.....	B-1
B.1	COM1 Serial Port	B-1
B.1.1	Connecting the Serial Device	B-1
B.1.2	Default Print Format.....	B-2
B.1.3	Full Duplex Modes for COM1	B-2
B.1.3.1	Demand Mode.....	B-2
B.1.3.2	Continuous Mode.....	B-3
Appendix C:	Error Messages.....	C-1
C.1	Error Messages.....	C-1
C.1.1	Operator Errors	C-1
C.1.2	Calibration Errors	C-2

LIST OF FIGURES

1-1	CSM Series Front Panel.....	1-1
2-1	CSM Back Panel.....	2-1
2-2	Latitude Compensation Zones (USA)	2-2
3-1	CSM Display Detail	3-1
3-2	Function and Numeric Keys Layout.....	3-2
5-1	User Menu Key Assignments.....	5-2
5-2	User Menu Chart.....	5-2
B-1	Pin Assignments for COM1 Serial Port.....	B-1
B-2	Cable Diagram for Scale to Dot Matrix Printer.....	B-1
B-3	Cable Diagram for Scale to Computer.....	B-1
B-4	Default Print Format.....	B-2
B-5	Consolidated Controls Demand Mode	B-2
B-6	Consolidated Controls Continuous Mode.....	B-3

LIST OF TABLES

1-1	CSM Series Product Matrix	1-1
3-1	CSM Series Annunciator Definitions.....	3-1
3-2	CSM Sampling Limits.....	3-4
5-1	User Menu Descriptions	5-3
6-1	Minimum / Recommended Calibration Test Weights	6-2
B-1	Recognized Host Commands	B-2

CHAPTER 1: INTRODUCTION TO THE TRANSCELL CSM SERIES DIGITAL COUNTING SCALE

The Transcell Model CSM Series Digital Counting Scale is an easy to use, high-resolution counting scale featuring keyboard tare and unit weight entry. It is equipped with many useful features that are normally found on more expensive scale products, including memory accumulator and target values.

The scale is available in four avoirdupois weight capacities and four metric weight capacities. Table 1-1 shows the CSM series product matrix.

Prior to using the scale, please read this user's guide carefully and completely. Store the manual in a safe and convenient place so it will be available if you have questions concerning the operation of the scale.

MODEL	CAPACITY / GRADUATION	MODEL	CAPACITY / GRADUATION
CSM-6	6 x 0.0005 lb	CSM-3M	3000 g x 0.2 g
CSM-12	12 x 0.001 lb	CSM-6M	6000 g x 0.5 g
CSM-30	30 x 0.002 lb	CSM-15M	15 x 0.001 kg (1 g)
CSM-60	60 x 0.005 lb	CSM-30M	30 x 0.002 kg (2 g)

TABLE 1-1: CSM Series Product Matrix

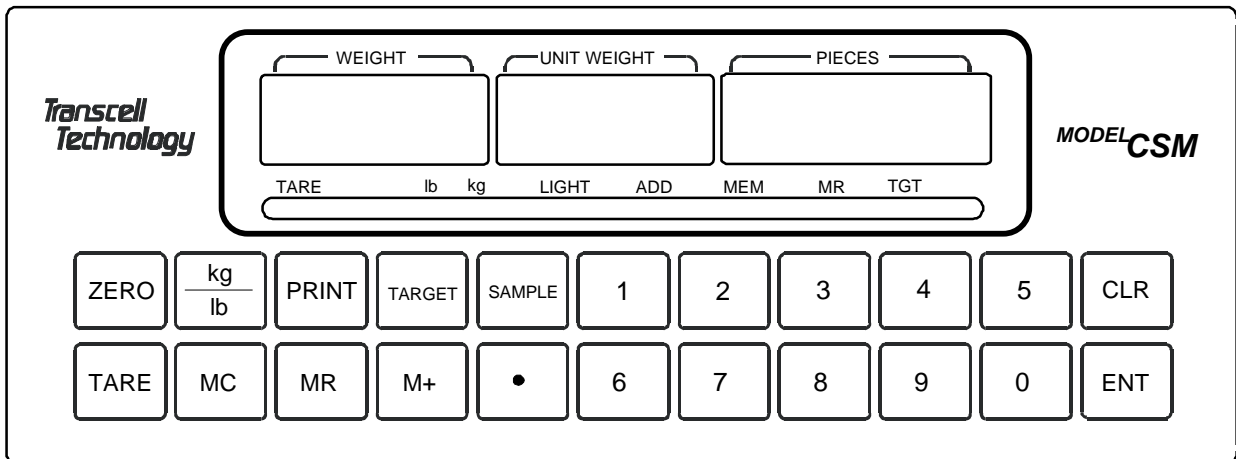

FIGURE 1-1: CSM Series Front Panel

CHAPTER 2: GETTING STARTED

After unpacking the scale, a small amount of preparation is required before the scale can be used. Please refer to Figure 2-1 below as needed.

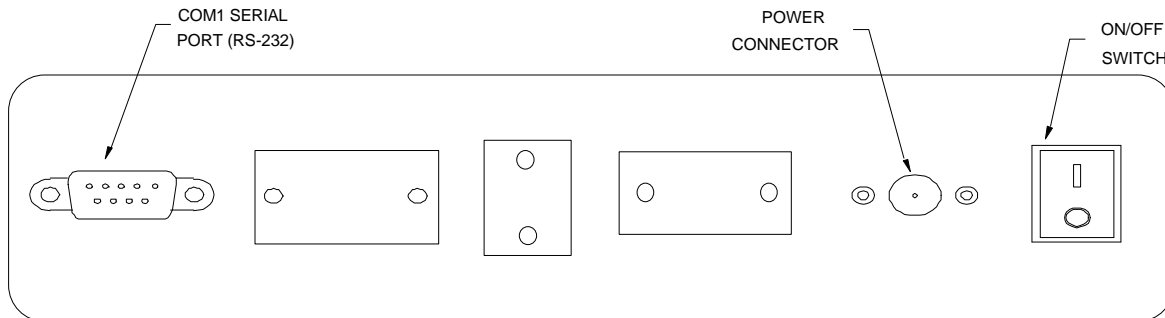

Figure 2-1: CSM Back Panel

- Step 1. Position the scale in its area of intended use. Observe the following guidelines for suitable location.
1. Choose a firm, stable floor or table.
 2. Do not share an AC outlet with electrical noise producing equipment, such as refrigeration units. This includes products with electrical motors and/or relays.
 3. Do not place the scale in an area with changing ambient temperature and/or high humidity.
 4. Do not place the scale in an area prone to exposure to direct sunlight, wind, or dust.
 5. Do not place the scale in an area with vibrating equipment.
- Step 2. Install the AC Adapter.
1. After placing the scale in its area of use, locate the Model A41408 (North America) or Model SA10-1208U (International) AC Adapter.
 2. Connect the female end of the AC Adapter to the connector on the rear of scale, and then plug the adapter into an AC outlet. **Make sure that the AC voltage appearing at the wall outlet matches the input voltage marked on the AC adapter.**
- Step 3. If applicable, install the serial printer or a computer to the COM1 serial port.
1. Connect the printer or computer to the COM1 port using the optional serial cable. See Appendix B for cabling requirements and pinouts.
 2. Configure the communication parameters and select the device type as detailed in Section 5.3.
- Step 4. Turn the scale's AC power on to begin use. When the scale is switched on for the very first time, the message "d-ZonE" appears on the display. Press the numeric key corresponding to the correct geographic area in the map shown in Figure 2-2 then press the **ENTER** key to save. **Note** – If there is no corresponding geographic area, enter "0" then press the ENTER key. No gravitation adjustment will be performed.

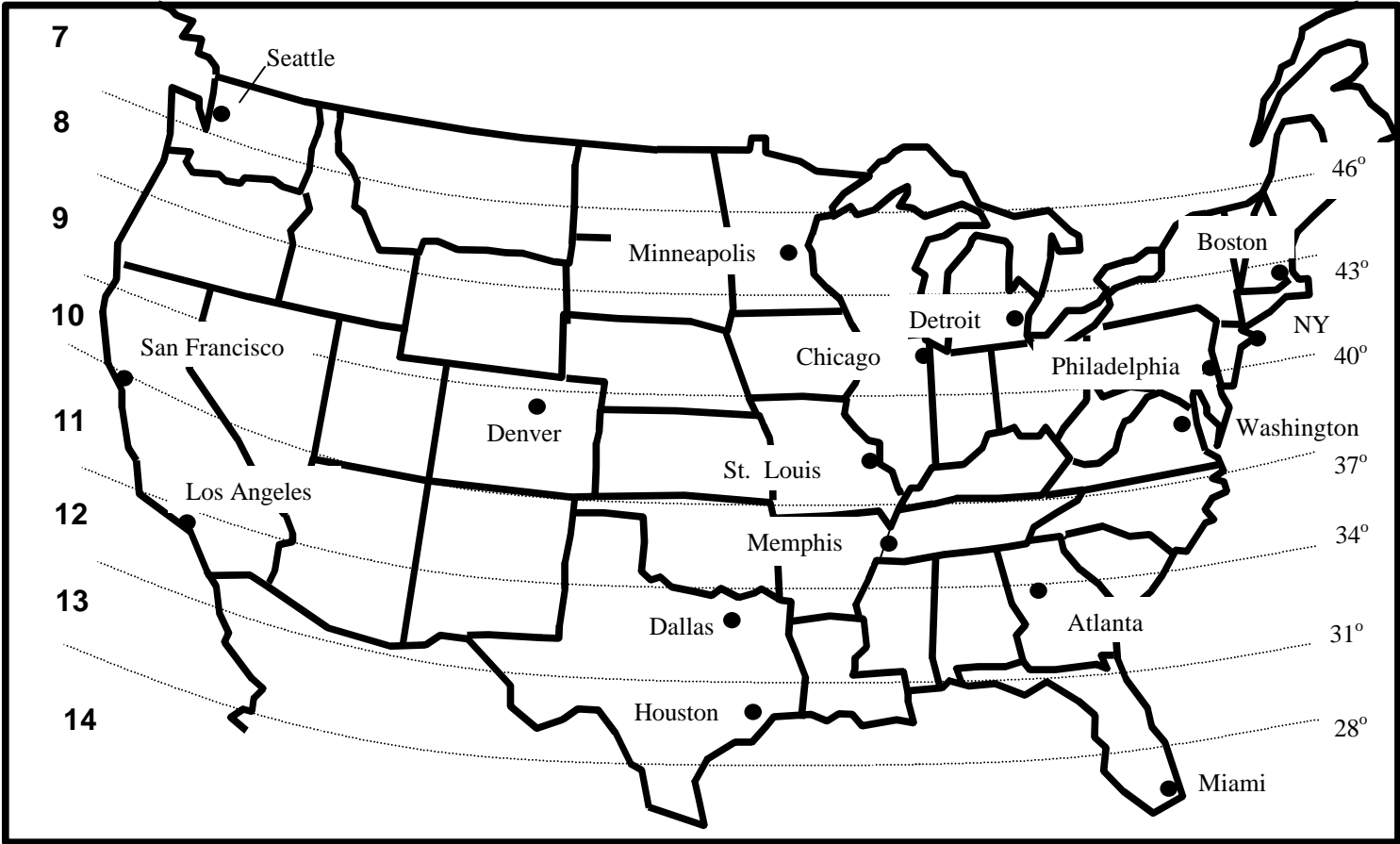

Figure 2-2 : Latitude Compensation Zones (USA)

CHAPTER 3: OPERATION

3.1 DISPLAY

The Model CSM scale utilizes a 16 digit VFD (Vacuum Fluorescent Display) to display the weight and system information.

3.1.1 VACUUM FLUORESCENT DISPLAY (VFD)

Figure 3-1 shows the display detail of the VFD. Table 3-1 lists the various annunciators you may see and their meanings.

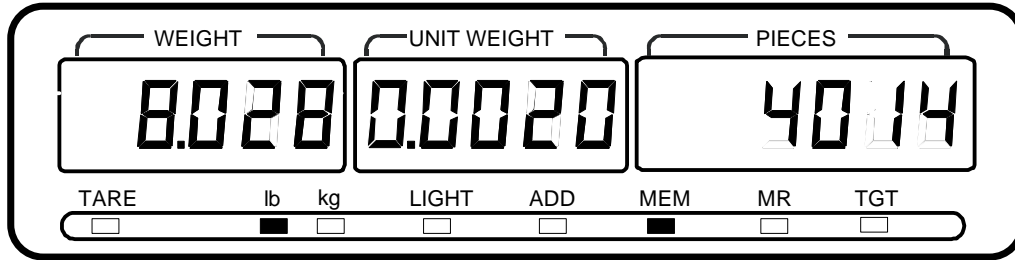

FIGURE 3-1: CSM Display Detail

Annunciator	MEANING
TARE	Indicates that a tare has been established in the system.
LB, KG	Indicates the unit of the displayed weight.
LIGHT	Indicates that unit weight of the items you are sampling or manually entering is too light for the scale to process accurately.
ADD	Indicates that total weight of the items you are sampling is too light for the scale to process accurately.
MEM	Indicates that the value of the piece count accumulator is greater than zero.
MR	Indicates that the scale is displaying the contents of the piece count accumulator.
TGT	Indicates that the number of pieces on the scale meets or exceeds the programmed target value.

TABLE 3-1: CSM Series Annunciator Definitions

3.2 KEYBOARD

The keyboard is composed of twelve function keys and ten numeric keys. Refer to Figure 3-2 for the overall layout and key locations.

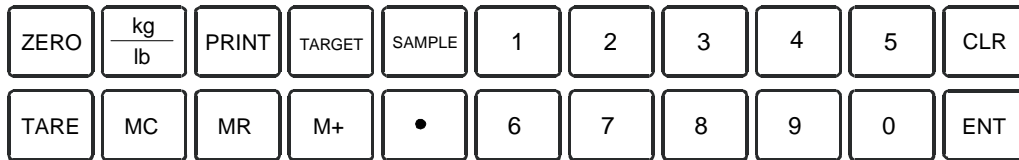

FIGURE 3-2: Function and Numeric Keys Layout

3.2.1 FUNCTION AND NUMERIC KEYS

Zero - This key sets the scale to display zero.

kg/lb – This key toggles the scale between pound (lb) and kilogram (kg) weight units.

Print - This key is used to send weight information out to the serial interface port provided the scale is in a state of stability.

Target - This key is used to set a target for filling and check weighing. Refer to Section 4.3 for more information.

Sample – This key is used to sample the items currently on the scale's platter for piece counting. Refer to Section 3.3.5 for more information.

Tare - This key is used to establish a Tare provided the scale is not at or below Gross zero. See Sections 3.3.2 and 3.3.3 below for more information.

MC - This key is used to clear the piece count accumulator.

MR - This key is used to briefly display the contents of the piece count accumulator.

M+ - This key is used to add the currently displayed number of pieces to the piece count accumulator.

Decimal Point - This key is used to enter a decimal point when entering numeric values.

0-9 – These keys are used to enter numeric and alphanumeric data into the scale.

CLR - This key is used primarily to erase a keyed-in value from the display in case an error has been made. This key is also used to clear the current APW (Average Piece Weight) from the scale.

ENT - This key is used to set a keyed-in value from the display as the new APW (Average Piece Weight). See Section 4.1 for more information. This key is also used to save settings while in the system setup menus. See Chapter 5 for more information.

3.3 GENERAL SCALE OPERATION

3.3.1 WEIGHING AN ITEM

1. If necessary, press the Zero key to obtain a weight reading of zero.
2. Place the object to be weighed on the scale's platter and allow the weight indication to stabilize. If the item weight exceeds the scale's weight capacity, it displays "o o o o o".
3. Read the weight shown on the display.

Note: If you wish to change the unit of measure, press the kg-lb key.

3.3.2 TARING AN ITEM OF UNKNOWN WEIGHT

To weigh an item in a container, the weight of that container must first be subtracted from the overall weight to obtain an accurate weight reading. This is known as taring.

1. If necessary, press the Zero key to obtain a weight reading of zero.
2. Place the empty container on the scale's platter and allow the weight indication to stabilize.
3. Press the Tare key. The TARE light comes on and the scale displays a weight reading of zero.
4. Place the material to be weighed in the container and allow the weight indication to stabilize.
5. Read the weight shown on the display.

3.3.3 TARING AN ITEM OF KNOWN WEIGHT

If the weight of the container or object is known, you may enter this weight via the keyboard. This value must be rounded to the nearest scale division. For example, on a 60 x 0.005 lb scale, you must enter the tare weight value to the nearest 0.005 lb.

1. Using the numeric keys, key-in the known tare weight and press the Tare key. The display shows minus weight and turns the TARE annunciator on.
2. Place the material to be weighed in the container and allow the weight indication to stabilize.
3. Read the weight shown on the display.

3.3.4 CLEARING A TARE

1. To clear a tare, press the ZERO key at any time. The TARE annunciator disappears and the gross weight is displayed.

3.3.5 PIECE COUNTING

This mode is used to indicate the number of pieces of an item you have placed on the scale's platform. To ensure accuracy, the parts you are counting must be consistent in weight.

The scale uses the sampling method to determine the average piece weight (APW) of the items you wish to count. When sampling items, always count the parts in your hand and place them on the platform all at once. If the APW of the items is too light or the total weight of the sample is too light, accuracy cannot be guaranteed. You will get an error message, but piece counting will still be allowed. Consult Table 3-2 for minimum piece weights and sample weights.

1. If the items you will be counting require a container, you must first tare the container off by pressing the TARE key. The scale switches to TARE mode and sets the displayed weight to zero.
2. Place the sample items on the platform all at once.
3. Using the numeric keys, key-in the number of items you have placed on the scale's platter.

4. Press the SAMPLE key. If the sample meets the limits shown in Table 3-2, the scale will now display the number of pieces on the scale. If it does not, the scale lights one of the error annunciators but still allows piece counting. If this occurs, you should use a higher sample amount to achieve better piece count accuracy. Please see Table 3-1 for an explanation of the error annunciators.

NOTE1 : If the scale displays a “Error 10” message, the unit weight of the items you wish to count is too light for your scale to process at all.

NOTE2 : To further increase the accuracy of this operation, the CSM uses a feature called "Automatic Average Weight Improvement" (AAWI). This feature automatically updates the current APW when small quantities of pieces – two to current piece count – are added to the platform. For example, if the current piece count shown on the display is 10, then adding 2 to 10 more pieces on the platform at the same time will trigger AAWI. When this occurs, the Unit Wt. Screen will show dashes briefly then update the new APW value.

3.3.6 CLEARING THE PIECE COUNT

1. To clear the piece count, either press the CLR key to erase the sample or repeat the steps in Section 3.3.5.

MODEL	Capacity / Graduation	Minimum Piece Weight	Minimum Sample Weight
CSM-6	6 x 0.0005 lb	0.0004 lb	0.0125 lb
CSM-12	12 x 0.001 lb	0.0008 lb	0.025 lb
CSM-30	30 x 0.002 lb	0.0016 lb	0.050 lb
CSM-60	60 x 0.005 lb	0.004 lb	0.125 lb
CSM-3M	3000 g x 0.2 g	0.16 g	5 g
CSM-6M	6000 g x 0.5 g	0.4 g	12.5 g
CSM-15M	15 x 0.001 kg (1 g)	0.8 g	25 g
CSM-30M	30 x 0.002 kg (2 g)	1.6 g	50 g

TABLE 3-2: CSM Sampling Limits

CHAPTER 4: ADVANCED FEATURES AND OPERATION

4.1 UNIT WEIGHT ENTRY

If you already know the unit weight (a.k.a. Average Piece Weight or APW) of the items you wish to count, then use the following procedure.

4.1.1 UNIT WEIGHT ENTRY

1. Using the numeric and decimal point keys, key-in the actual unit weight value.
2. Press the ENT key. If the unit weight is large enough, the scale will now display the number of pieces on the scale. If it does not, the scale briefly displays an error message, but still allows piece counting. Please see Appendix C for an explanation of the error messages.

NOTE 1: If the scale displays a “Error 10” message, the unit weight of the items you wish to count is too light for your scale to process at all.

4.2 MEMORY ACCUMULATOR

Your scale comes equipped with a handy memory accumulator, which can be used in conjunction with the piece counting feature. As with a hand-held calculator, the memory accumulator can be added to, displayed and cleared at anytime.

NOTE: This feature can be used for pieces only.

4.2.1 DISPLAYING THE MEMORY ACCUMULATOR

1. Press the MR key. The scale briefly displays the total number of pieces.

4.2.2 ADDING TO THE MEMORY ACCUMULATOR

1. Press the M+ key. The scale adds the current number of pieces to the memory accumulator.

4.2.3 CLEARING THE MEMORY ACCUMULATOR

1. Press the MC key.

4.3 USING THE TARGET VALUE

This function works in conjunction with the piece counting feature and allows your scale to act as a checkweigher. This is useful if you are filling a container with a pre-determined amount of items.

To use, you must enter a target value. For example, if you wish to fill a bottle with 100 items you would set your target value to 100.

If the number of items on the platform matches or exceeds the target value, the scale the flashes the TGT annunciator and beeps.

1. Use the numeric keys to key-in the target value then press the TARGET key.
2. Place items on scale until the scale signals that the items are equal to or greater than the target value.

NOTE: To exit the target function, press the TARGET key once.

CHAPTER 5: CONFIGURATION

5.1 CONFIGURATION OVERVIEW

The scale contains two main setup menus: The Setup (“F”) menu configures the factory settings for your scale. The User (“A”) menu configures the COM1 serial communication port and enables some user options. The Setup and User menus consist of several menu selections, each with its own sub-menu of choices.

To set up the scale, you must first enter the appropriate menu mode. Once there, four of the front panel keys become directional navigators to move around in the menus, and one key is used to save or SET the selections.

5.2 SETUP (“F”) MENU

The Setup (“F”) Menu is considered too technical for the operation guide. Please refer to the CSM Service Manual for complete coverage.

5.3 USER (“A”) MENU

5.3.1 ENTERING THE USER MENU

1. Toggle the ON/OFF switch to the OFF (0) position.
2. Press and hold the 8 key while powering back on the scale. When the scale shows “A 1” you are in User Menu mode and you may release the 8 key.

5.3.2 NAVIGATING IN THE USER MENU

Use the directional keys shown in Figure 5-1 to move around in the User Menu Chart shown in Figure 5-2 on the following page. Detailed descriptions of the User Menu can be found in Table 5-1.

1. To move to a new “A” heading, use the 4 (left) or 5 (right) key to move right or left in the User Menu Chart.
2. To move to the selection level, press the 2 (down) key once. The current saved selection is shown.
3. To view the available selections for the current “A” heading, use the 4 (left) or 5 (right) key to move through the selection field.
4. To save a new selection, press the ENT (Set) key .To exit without saving, press the 1 (up) key to return to the current “A” heading.
5. Repeat Steps 2 through 5 until the User Menu is programmed.

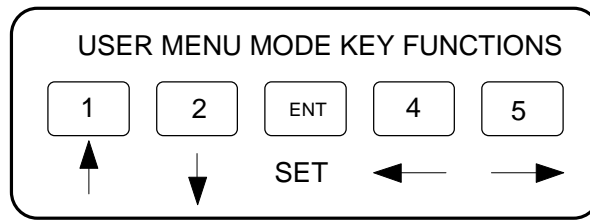

Figure 5-1: User Menu Key Assignments

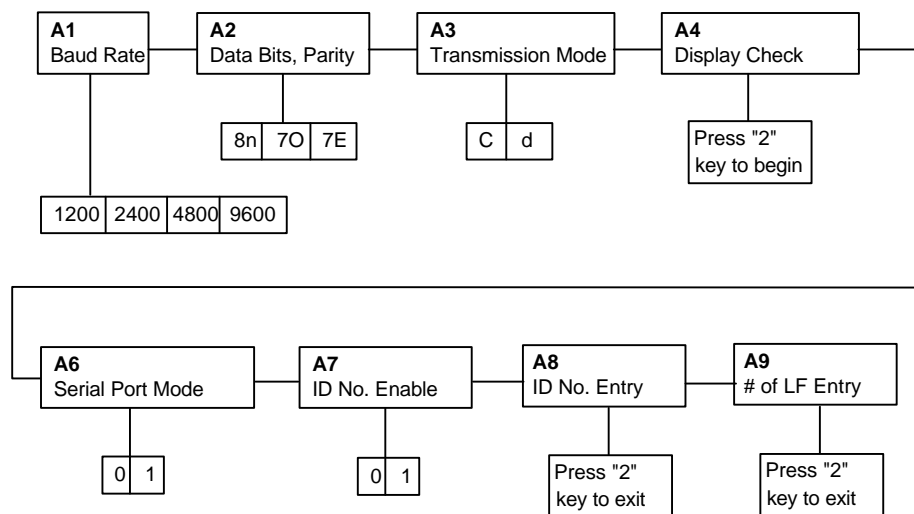

Figure 5-2: User Menu Chart

5.3.3 EXITING THE USER MENU

1. Toggle the ON/OFF switch to the OFF (0) position.
2. Turn the scale back on without holding down any keys. The display will go through a digit check, then settle into Normal Operating mode. All front panel keys will now return to their normal mode of operation.

NAME/CODE	DESCRIPTION	CODE/VALUE
A1 Baud Rate	Selects the baud rate for data transmission through the serial port.	1200 2400 4800 9600 √
A2 Data Bits and Parity	Selects the number of data bits and parity of serial transmission. "8n" = 8 data bits with no parity bit "7O" = 7 data bits with odd parity bit "7E" = 7 data bits with even parity bit	8n √ 7O 7E
A3 Mode of Serial Transmission	Selects when data will be sent out of the serial port to a printer or computer: "C" = Continuous mode; send data continuously "d" = Demand mode; send data when a PRINT command is issued from the printer, computer, or indicator.	C d √
A4 Display Check	Actuates the function that illuminates all digit segments, decimal points, and LED annunciators in a test sequence. Pressing the 2 key to scroll down one level begins the test sequence.	Press 2 key to begin sequence
A6 Serial Port Mode	Selects the mode of the RS-232C serial port: "0" = Full Duplex Mode "1" = Print Ticket Mode	0 √ 1
A7 ID No. Enable	Allows the ID No. to be disabled in the printout. Valid only when A6 is set to "1". "0" = Disable the ID No. "1" = Enable the ID No.	0 √ 1
A8 ID No. Entry	Actuates the function which allows entry of a new ID No. Valid only when A6 is set to "1". Pressing the 2 key to scroll down one level begins the sequence.	0 - 999999 (123456 is default)
A9 No. of Line Feeds	Actuates the function which allows entry of the desired number of line feeds to be printed after the printout. Valid only when A6 is set to "1". Pressing the 2 key to scroll down one level begins the sequence.	0 – 99 (5 is default)

Table 5-1: User Menu Descriptions

5.4 USER MENU PROCEDURES

This section provides instructions for all of the User Menu procedures.

5.4.1 ID Number Entry (A8)

1. While in the User Menu mode, scroll to "**A 8**", then scroll down once using the **2** key to enter the ID Number menu.
2. The display will momentarily show "**ET ID**", followed by the current ID number value.

3. Use the front panel numeric keys to key-in the actual ID Number value. If you make a mistake, press the CLR key to clear your entry and start over.
4. After entering the exact value, press the ENT key to save the ID Number value. The display will show " **END ID** " momentarily, then revert back up to A8.

5.4.2 LF (Line Feeds) Number Entry (A9)

1. While in the User Menu mode, scroll to "**A 9**", then scroll down once using the 2 key to enter the Line Feeds menu.
2. The display will momentarily show "**ET LF**", followed by the current line feeds value.
3. Use the front panel numeric keys to key-in the actual line feeds value. If you make a mistake, press the CLR key to clear your entry and start over.
4. After entering the exact value, press the ENT key to save the line feeds value. The display will show " **END LF** " momentarily, then revert back up to A9.

CHAPTER 6: CALIBRATION

6.1 CALIBRATION OVERVIEW

Your CSM scale ships from the factory fully calibrated. There is no need to calibrate the scale unless you feel that it has become inaccurate. It is a good idea to check the calibration of your scale from time to time with a precision test weight. Transcell recommends that you perform a new calibration on your digital scale at least once a year.

During calibration, at least two values are saved in the scale's memory – the zero value (deadweight) and the up to three span values (test weights). See Table 6-1 for a listing of minimum and recommend test weights.

6.2 CALIBRATION MODE

1. Toggle the ON/OFF switch to the OFF (0) position.
2. Press and hold the ZERO key while powering back on the scale. When the scale shows "o Zone" you are in Calibration mode and you may release the ZERO key.
3. Press the ENT key. The scale shows "C 0" on the middle screen and displays a value on the right hand screen. The "C 0" indicates that the scale is prompting for the zero calibration value. The value to the right is for troubleshooting purposes only. Allow a 20-minute warm-up period for the load cell and electronic components to become thermally stable.
4. Remove all items from the scale's platter. Press ZERO to zero the value.
5. Press the ENT key to save the zero point value. The scale shows "0.000" on the left screen, "C 1" on the middle screen and a value on the right screen. The "C 1" indicates that the scale is prompting for the first span calibration value. The value to the right is for troubleshooting purposes only.
6. Use the numeric keys to enter the test weight value. Please note that the decimal point is fixed so that if you are entering, for example, 6 lb, you need to type "6" followed by zeroes until the "6" is to the left of the decimal point.
7. Place the test weight(s) onto the scale's platter, then press the ENT key. If the calibration was successful, the display will show "END C1" momentarily, then prompt for the next span calibration value.
8. If you wish to use up to two more calibration test weights, repeat Step 7 twice. Each subsequent test weight must be greater than the last. If you do not wish to use more calibration test weights, simply press ENT twice. The scale then automatically enters Normal Operating Mode by performing a countdown test. Remove the test weight from the platter

NOTE: If you encounter a failure, consult Appendix C for possible causes and remedies.

MODEL	Capacity / Graduation	Minimum Test Weight	Recommended Test Weight
CSM-6	6 x 0.0005 lb	0.06 lb	4 lb to 6 lb
CSM-12	12 x 0.001 lb	0.12 lb	8 lb to 12 lb
CSM-30	30 x 0.002 lb	0.3 lb	20 lb to 30 lb
CSM-60	60 x 0.005 lb	0.6 lb	40 lb to 60 lb
CSM-3M	3000 x 0.2 g	30 g	2 kg to 3 kg
CSM-6M	6000 x 0.5 g	60 g	4 kg to 6 kg
CSM-15M	15 x 0.001 kg (1 g)	150 g	10 kg to 15 kg
CSM-30M	30 x 0.002 kg (2 g)	300 g	20 kg to 30 kg

TABLE 6-1: Minimum / Recommended Calibration Test Weights

APPENDIX A: SPECIFICATIONS

CONSTRUCTION:

Housings: Gray ABS
Sub-Platform: ABS
Platter: Stainless Steel
Feet: Non-skid Hard Rubber

DISPLAY:

14 Character, 7-Segment VFD

KEYPAD:

22-key Tactile Keypad

OVER CAPACITY ANNUNCIATION:

103% of Full Scale Capacity

OPERATING TEMPERATURE RANGE:

32°F to 104°F
(0°C to 40°C)

POWER SOURCE:

AC Adapter, 12VDC, 800 mA,
included

COM1 SERIAL PORT:

Full Duplex RS-232, DSUB9F

WEIGHT:

Net Weight: 11.0 lb (4.9 kg)
Shipping Weight: 12.6 lb (5.7 kg)

PHYSICAL DIMENSIONS:

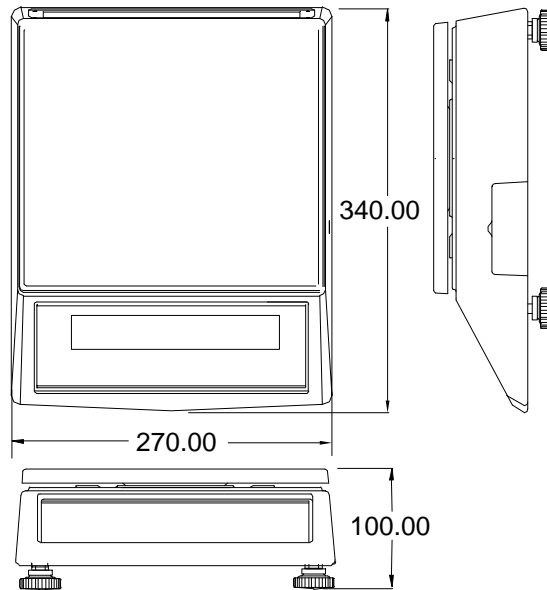

All units in mm.

APPENDIX B: SERIAL PORT INFORMATION

B.1 COM1 SERIAL PORT

B.1.1 CONNECTING THE SERIAL DEVICE

The COM1 serial port is a full duplex RS-232 port designed for connection to a serial printer, computer, or remote display. Figure B-1 shows the serial port pinout. Figure B-2 shows a suggested cable diagram for a serial printer. Figure B-3 shows a suggested cable diagram for a PC-type computer. The cable shown in Figure B-3 is a standard Transcell cable – Model NMC-1.

1. Plug the serial device cable (not included) directly into the DSUB9 serial port connector.

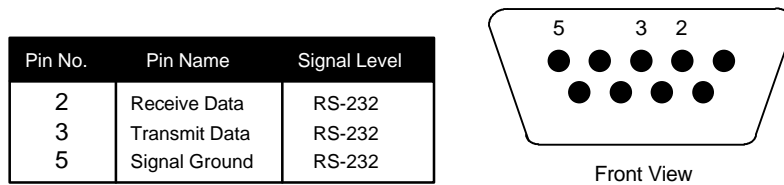

Figure B-1: Pin assignments for the COM1 serial port connector

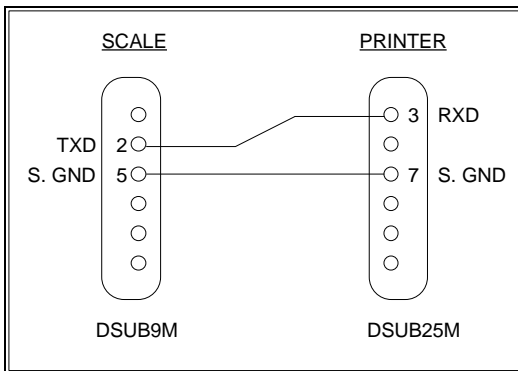

FIGURE B-2: Cable Diagram for Scale to Dot Matrix Printer

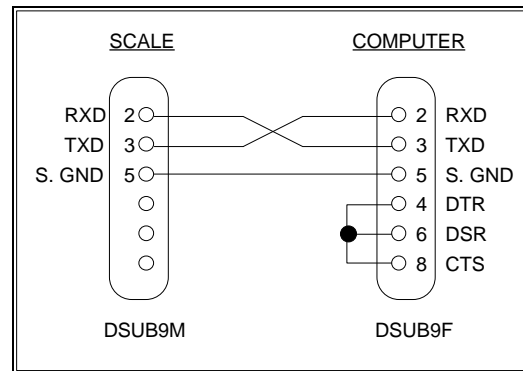

FIGURE B-3: Cable Diagram for Scale to Computer

B.1.2 DEFAULT PRINT FORMAT

Figure B-4 shows the fixed format of the print format. **NOTE:** The TARE and NET fields are blank when a tare has not been established in the system. The PCS field is blank when a unit weight has not been established in the system.

ID. NO.	123456
GROSS	5. 000 LB
TARE	1. 480 LB
NET	3. 520 LB
PCS	3520

FIGURE B-4: Default Print Format

B.1.3 FULL DUPLEX MODES FOR COM1

B.1.3.1 DEMAND MODE

The Demand mode allows control from a host device, usually a PC, and can be activated by pressing the Print soft key. Figure B-5 shows the serial data format for the Demand Mode. Table B-1 shows the recognized host commands.

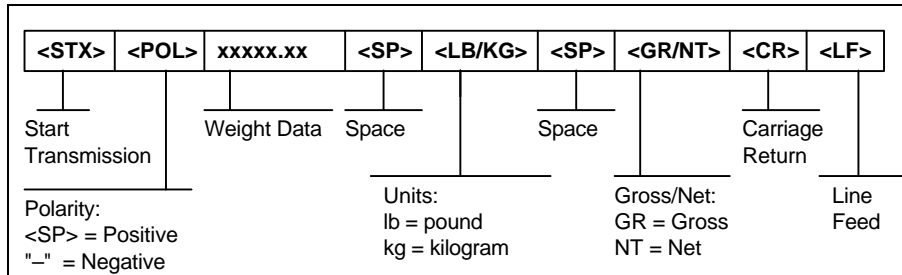

FIGURE B-5. Consolidated Controls Demand Mode

- “**P**” - This command is sent to the scale to print the indicated display. The scale will not respond if the scale is in motion, positive overload or negative overload.
- “**Z**” - This command is sent to the scale to zero the scale. If the scale is in motion, the scale will wait until a state of equilibrium is achieved. The scale will not respond at all if the scale is in positive overload or negative overload.
- “**T**” - This command is sent to the scale to tare the scale. If the scale is in motion, the scale will wait until a state of equilibrium is achieved. The scale will not respond at all if the scale is in positive overload or negative overload. The scale will also not respond if it displaying a negative gross value.
- “**C**” - This command is sent to the scale to toggle among the configured units.

TABLE B-1. Recognized Host Commands

B.1.3.2 CONTINUOUS MODE

The Demand mode is used to interface to computers, scoreboards and other remote devices requiring constant data updating. The transmission occurs at the end of each display update. Figure B-6 shows the serial data format for the Continuous Mode.

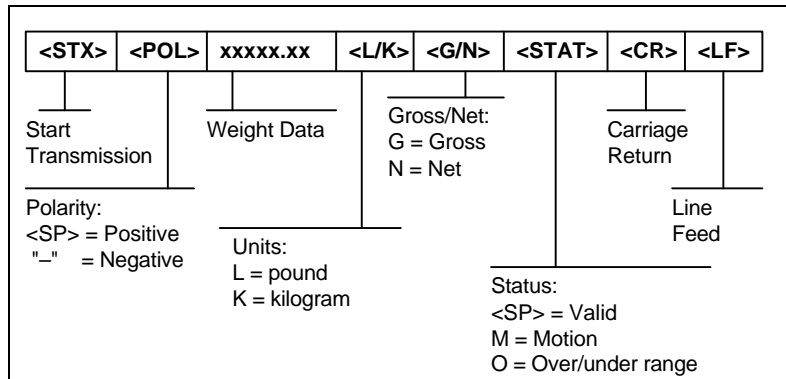

FIGURE B-6. Consolidated Controls Continuous Mode

APPENDIX C: ERROR MESSAGES

C.1 ERROR MESSAGES

If the scale encounters an error condition, it will display a message alerting the operator. A description of each display follows:

C.1.1 OPERATOR ERRORS

Message	Explanation
□□□□□□	Indicates that the weighing capacity of the selected scale has been exceeded.
Err 9	Span calibration value has been lost. Re-calibrate scale.
Err 10	Indicates that there is not enough internal resolution to calculate the unit weight of an item. This means that the items you are counting are too light for the scale to process at all.
Err 11	Keyed-in sample value is equal to zero or is a fractional value. Key-in a valid sample value.
Err 12	Indicates that unit weight of the items you are sampling or manually entering is too light for the scale to process accurately.
Err 13	Indicates that total weight of the items you are sampling is too light for the scale to process accurately.
Err 14	The keyed-in value for unit weight is equal to zero or exceeds the capacity of the scale. Key-in a valid unit weight value.
tErr 6	Indicates that the tare weight value you are entering is not rounded to the nearest scale division. For example, you cannot enter 0.01 lb for a 0.05 lb increment scale.
tErr 1	Indicates that the tare weight value or unit weight value you are entering exceeds the capacity of the scale.

C.1.2 CALIBRATION ERRORS

Message	Explanation
Err 0	Indicates that the test weight value you have chosen exceeds the scale's capacity.
Err 1	Indicates that the test weight value you have chosen is less than 1% of the scale's capacity.
Err 2	Occurs when you do not place the test weight on the scale during calibration. Can also indicate that there is an internal error in the scale.

LIMITED WARRANTY

Seller warrants that the CSM Series Digital Counting Scale will conform to written specifications, drawings, and other descriptions made by the manufacturer, including any modifications thereof. The Seller warrants the goods against faulty workmanship and defective materials. If any goods fail to conform to these warranties, Seller will, as its sole and exclusive liability hereunder, repair or replace such goods if they are returned within the following warranty period:

Twelve (12) months from date of shipment from manufacturer.

These warranties are made upon the express condition that:

- 1) Transcell Technology, Inc. is given prompt written notice upon discovery by Buyer of such non-conformity, with a detailed explanation of the alleged deficiencies;
- 2) Such goods are returned to the Seller at the expense of the Buyer;
- 3) Examination of such goods by Seller discloses that the nonconformity actually exists and was not caused by accident, misuse, neglect, alteration, improper installation improper or unauthorized repair, or improper testing, and
- 4) Such goods have not been modified, altered, or changed by any person other than the Seller or its duly authorized repair agents.
- 5) Transcell Technology, Inc. will have a reasonable time to repair or replace such goods.

THESE WARRANTIES EXCLUDE ALL OTHER WARRANTIES, EXPRESS OR IMPLIED, ORAL OR WRITTEN, INCLUDING WITHOUT LIMITATION WARRANTIES OF MERCHANTABILITY OR FITNESS FOR A PARTICULAR PURPOSE. SELLER WILL NOT IN ANY EVENT BE LIABLE FOR INCIDENTAL OR CONSEQUENTIAL DAMAGES.

IN ACCEPTING THIS WARRANTY, THE PURCHASER OR BUYER AGREES TO WAIVE ANY AND ALL OTHER CLAIMS FOR RIGHT TO WARRANTY FROM TRANSCCELL TECHNOLOGY, INC. SHOULD THE SELLER BE OTHER THAN TRANSCCELL TECHNOLOGY, INC., THE BUYER AGREES TO LOOK ONLY TO THE SELLER FOR WARRANTY CLAIM OR CLAIMS.

No terms, conditions, understanding, or agreements purporting to modify the terms of this warranty shall have any legal effect unless made in writing and signed by a corporate officer of the Seller.